



SPRINT



UNIGATE - I *INVERTER technology*

Hydraulic barrier for intensive use
and for beams up to 19,6 Ft

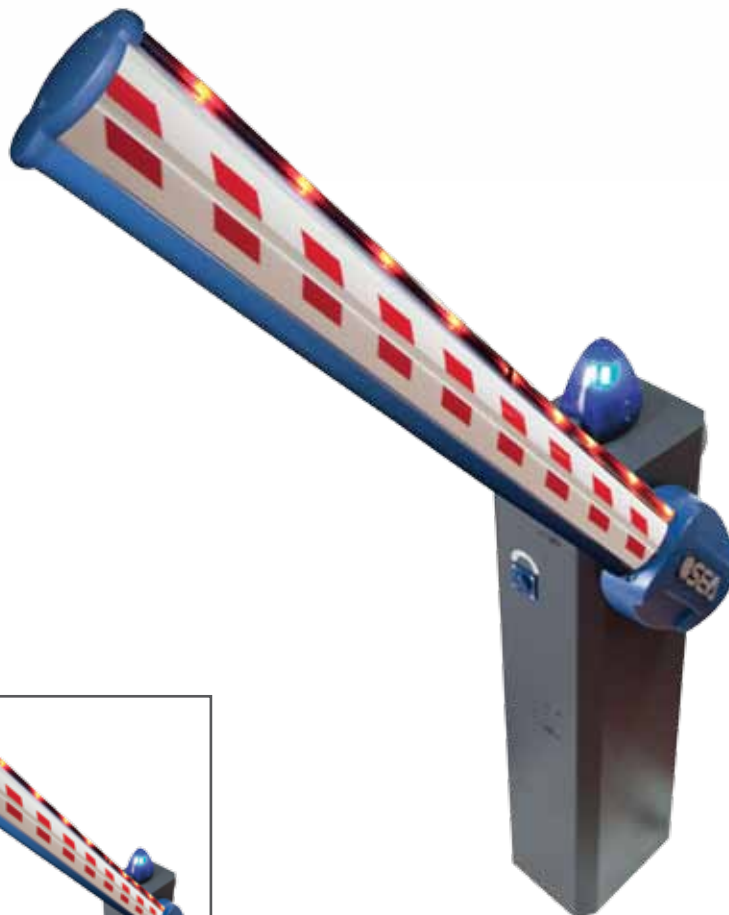

By pass valves

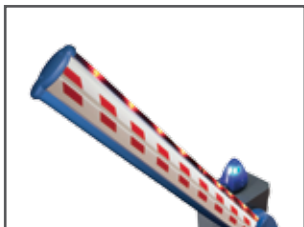

Oval aluminium beam
with protection rubber
and optional RGB strip
led light

- ▶ Fast and reliable automatic hydraulic barrier
- ▶ Longer life thanks to the operator working through oil and the inside lubrication of all the mechanical components
- ▶ Extremely silent thanks to hydraulic operating
- ▶ Adjustable mechanical stops
- ▶ Also electronic limit switches on request
- ▶ Cataphoresis treated and polyester painted steel casing for long time lasting
- ▶ INOX (316) steel casing available (on request)
- ▶ Casing pre-drilled with holes for photocells SUNSET and key switch ASTER
- ▶ Universal right / left hand side

SPECIFICATIONS	SPRINT with UNIGATE INVERTER
Power supply	115 Vac
Power Consumption (W)	200 W
Absorbed current	2,45 A
Opening delay	4 sec - 7 sec
Frequency of use	90%
Thermal protection	130°C
Operation temperature	-4°F to + 131°F
Weight	112 lbs
Max. beam length	19,6 ft
Protection class	IP55
Starting capacitor	60 µF

UNIGATE - I

INVERTER technology



UNIGATE (INVERTER)

- Digital control unit with LCD display
- Adjustable speed
- Adjustable acceleration/deceleration
- Continuous motor cycles
- High strength in slowdown
- Possibility to manage obstacle reverse

Integrated functions on the UNIGATE INVERTER

- 2 relay contacts
- 2 programmable GPIO outputs
- LE card on board for potentiometer
- Relay card on board
- PROBE heater card on board



SPRINT						
Beam model	3,0 m 10 fet	3,5 m 11,5 fet	4,0 m 13 ft	4,5 m 14,5 ft	5,0 m 16,5 ft	6,0 m 19,5 ft
LIGHT S (linear beam)	Green	White	Blue	White	Orange	Purple
LIGHT - ART (articulated arm)	White	Blue	White	White	White	White

Spring type	
(mm / inches)	
Ø 6,5 / 0,23	Green
Ø 7,0 / 0,27	Blue
Ø 8,0 / 0,31	Orange
Ø 9,0 / 0,35	Purple

ACCESSORIES



SUPL
Pliable support for oval beam

STICKER
Red sticker for beam (164 feet package)

CSUPLIGHT
Counter plate for fork support

RGB STRIP LED
Red light IP 65 - 16.5 Ft

LIGHTS-ART
Articulated oval beam up to max 11Ft

SF
Fork support

KIT LIGHT S 3-TH 10 feet
KIT LIGHT S 4 - TH 13 feet
KIT LIGHT S 5 TH -16,5 feet
Oval beam + balancing spring with blunt free rubber + profile LED (Sticker not included)

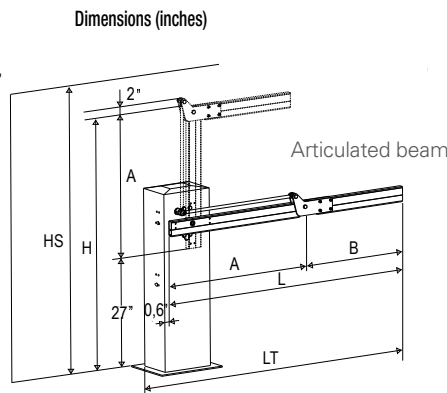
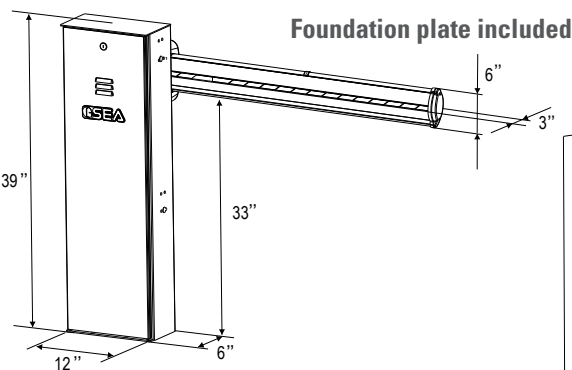

PACKAGE SPRINT

- N.1pc SPRINT with control board UNIGATE
- N.1pc Installation accessories Kit
- N.1pc Installation instructions and general notice
- N.1pc Foundation plate
- N.1pc Warning signboard



SEA USA Inc.
10850 N.W. 21st Street - Unit 160 - 33172 Miami - Florida (USA)
Phone: +1-305.594.1151 - Fax: +1-305.594.7325

www.sea-usa.com