



VELA INDUSTRIAL Brake with Unigate Inverter

Hydraulic barrier for intensive use and for beams up to 24,5 Ft



 **UNIGATE - I**
INVERTER technology



Double fork coupling for oval beam



By pass valves for the force adjustment

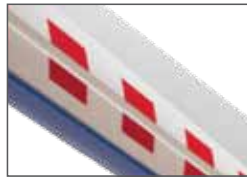

RGB Strip LED light IP65



Case opening



Mechanical and electronic limit switches

- ▶ The operation through oil and the inside lubrication of all mechanical components grant a longer life
- ▶ Adjustable mechanical limit switches
- ▶ Cathaphoresis treated, polyester painted steel casing for long time lasting. Stainless steel casing available
- ▶ Oval aluminium beam LINEAR with protection rubber and optional RGB STRIP LED light
- ▶ Also available modular beam SPLIT + JUICE with connection joint for easy transportation
- ▶ Universal right / left hand side
- ▶ Version with fixing for oval modular beam

SPECIFICATIONS	VELA INDUSTRIAL with UNIGATE INVERTER
Power supply	115 Vac
Power Consumption (W)	230 W
Absorbed current	1,1 A
Opening delay	6 sec - 7 sec
Frequency of use	90%
Thermal protection	130°C
Operation temperature	-4°F to + 131°F
Weight	182 lbs
Max. beam length	23 ft side fixing 24,6 ft fork fixing
Protection class	IP55
Starting capacitor	12,6 µF

UNIGATE - I

INVERTER technology



UNIGATE (INVERTER)

- Digital control unit with LCD display
- Adjustable speed
- Adjustable acceleration/deceleration
- Continuous motor cycles
- High strength in slowdown
- Possibility to manage obstacle reverse

Integrated functions on the UNIGATE INVERTER

- 2 relay contacts
- 2 programmable GPIO outputs
- LE card on board for potentiometer
- Relay card on board
- PROBE heater card on board



VELA INDUSTRIAL				Spring type		
Beam model	19,5 ft	23 ft	24,6 ft	(inches)		
JSF (SPLIT + JUICE) 2 pcs				Ø 0.4		cod. 6640010
SK SKIRT (SPLIT + JUICE) 2 pcs				Ø 0.45		cod. 6640011
SK2 SKIRT (SPLIT + JUICE) 2 pcs				Ø 0.47		cod. 6640020

ACCESSORIES



SUPL
Pliable support for oval beam



STICKER
Red sticker for beam (164 feet package)



CSUPIND
Counter plate for fork support



RGB STRIP LED
light IP 65 - 16.5 Ft



SUPIND
Fork support



Oval beam 23 feet
Oval beam 24,6 feet + balancing spring with blunt free rubber + profile LED (Sticker not included)



Oval beam 19.5 feet (6m)
Oval beam 23 feet (7m)
Oval beam 24.6 feet (7,5m) in two pieces + fork + spring + blunt free rubber + profile for LED

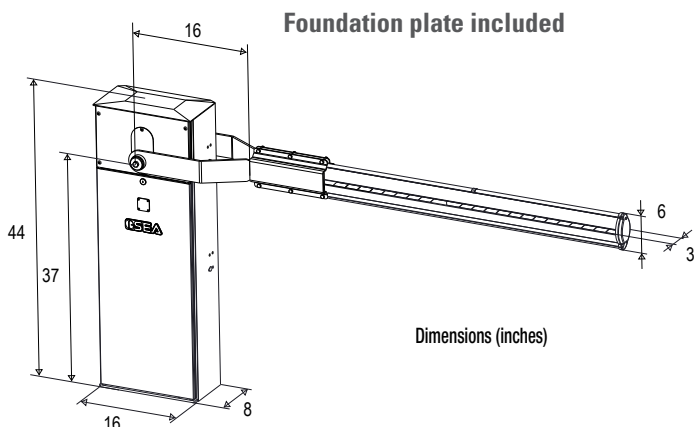

PACKAGE SPRINT

- N.1pc VELA INDUSTRIAL with control board UNIGATE
- N.1pc Installation accessories Kit
- N.1pc Installation instructions and general notice
- N.1pc Foundation plate
- N.1pc Warning signboard